



Job-made ladders for construction

This data sheet covers the fabrication and installation of ladders usually made on the job and installed in a semi-permanent location as means of employee travel between elevations.

2. Job-made ladders are normally not as portable as wood or metal ladders, and are not intended as replacements for portable ladders.

3. As permanent stairways and ladders are installed and ready for use at the job site, the job-made ladders should be removed.

4. The minimum lumber sizes and maximum ladder lengths and widths recommended in this data sheet will meet American National Standards Institute strength requirements for all species of lumber (see Appendix A).

Common hazards for job-made ladders

5. The falling hazard of climbing and descending any ladder is serious, even under the best circumstances, but with job-made ladders this hazard can be compounded by improper fabrication, faulty installation or use after a ladder or its base or top fastenings have been excessively worn or damaged.

6. Before mounting a ladder, personnel should check the soles of their shoes and clean any grease, oil, mud or other substances that could make climbing hazardous.

7. Personnel should always face the job-made ladder when ascending or descending, and use both hands on the ladder cleat or side rail.

8. Personnel should not climb job-made ladders while carrying materials in their hands. Use a handline for raising and lowering tools and materials, or approved alternative means.

9. Job-made ladders should never be used for any purpose (guys, braces, hoists and/or rigging supports, etc.) for which they are not designed.

Ladder fabrication Intended use determines double or single size:

10. Job-made ladders should be tailored to the intended use. Estimate the approximate amount of expected usage to determine if it will be a single-cleat ladder or a double-cleat ladder. For example, if the ladder will provide the only means of access to or egress from a main working area for 25 or more workers, or if simultaneous two-way traffic is expected, install a double-cleat ladder.

Proper ladder length

11. Determine the height the ladder is to reach and then add approximately 36-42 inches to allow the side rails to extend adequately above the top landing to provide a hand-hold for mounting and dismounting.

12. The maximum length of single-cleat ladders should not exceed 24 feet between supports (base and top landing). If ladders are to connect different landings, or if the length required exceeds this recommended maximum length, use two or more separate ladders, staggered, with a protected platform between each ladder. The maximum length of double-cleat ladders should not exceed 24 feet.

Ladder width

13. The width of single-cleat ladders shall be at least 16 inches, but not more than 20 inches, between rails at the top. The width between rails of double-cleat ladders shall not be less than 18 inches or more than 22 inches. Cleats shall be con-



tinuous members between the outside parallel rails (see Figures 1 and 2).

14. The width shall be uniform in the total length of the climb.

Lumber selection

15. ANSI A14.4, Safety Requirements for Job-Made Ladders, permits many species of lumber for cleat ladder fabrication. See Appendix A for various species of wood for use in job-made ladders.

16. All wood parts shall be seasoned to a moisture content of not more than 19 percent, reasonably straight-grained (no steeper than a 1-in-12 slope), dressed on all sides, and free from sharp edges and splinters.

17. Side rails must be free of knots. Cleats may contain knots providing the knots are sound, in the wide face, 0.75 inches or less in diameter, and not more frequent than two per cleat span or closer than 6 inches

on center. Knots are not permitted in the narrow faces of the lumber used for job-made ladders.

Note: Glossaries of wood defects are given in Appendices B and C.

Side rails

18. It is preferable that side rails be continuous. Structural finger-jointed lumber is permissible when full-length rail members cannot be procured. If splicing is necessary to attain the required length, however, the splice must develop the full strength of a continuous side rail of the same length.

19. The load-carrying capacity of side rails is a function of working length and pitch. The minimum rail sizes for various combinations of length and pitch for single- and double-cleat ladders shall comply with Tables I and II. Handrails should be prohibited on job-made ladders.

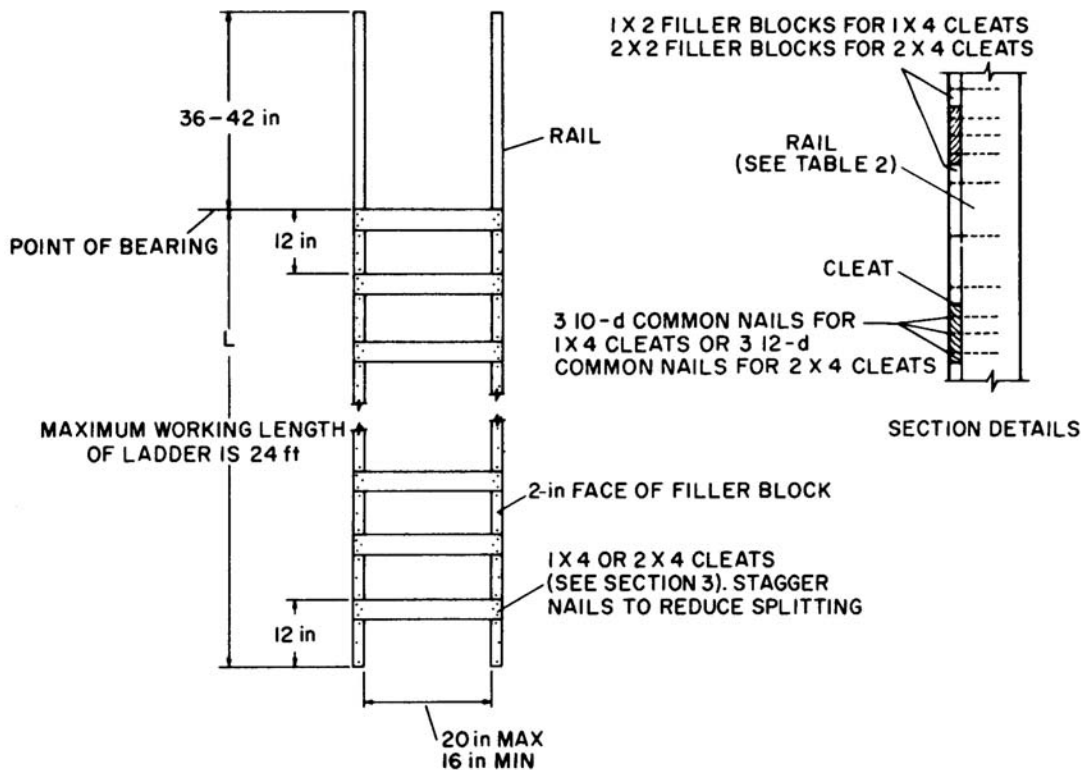

Figure 1. Scale drawing of a single-cleat ladder. It shows how the cleats are attached. All lumber sizes shown are nominal.

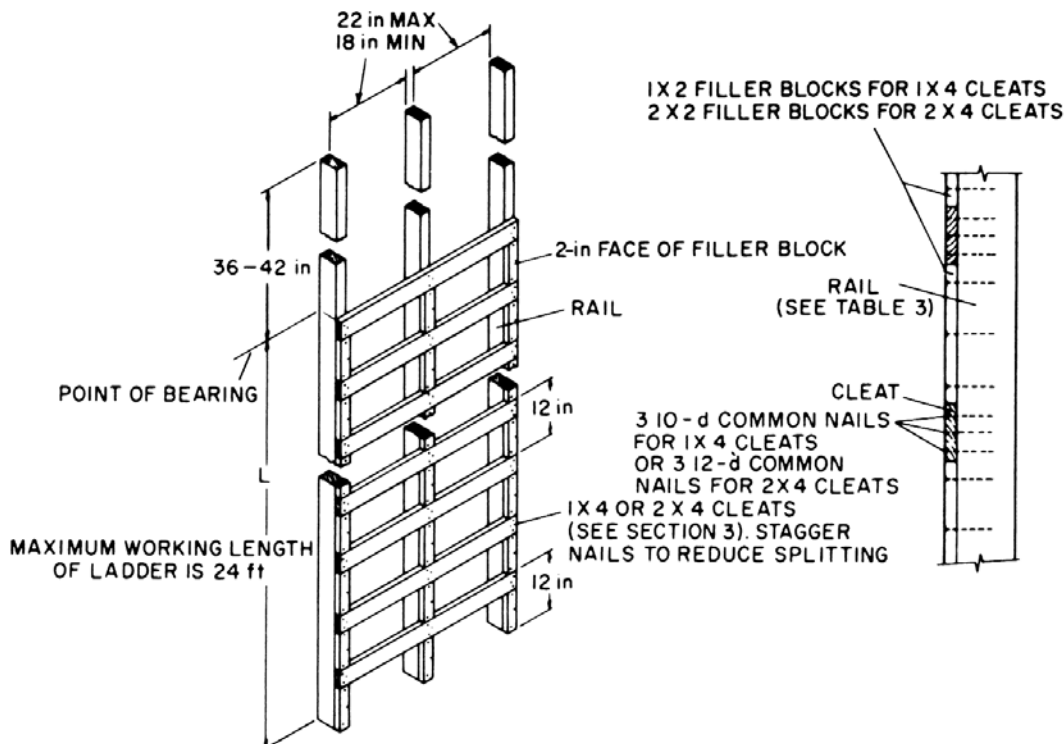

Figure 1. Cleat attachment for a double-cleat ladder.

Cleats

20. Nominal 1-inch by 4-inch board material is not normally subject to stress grade rules and shall be used after close site inspection ensures compliance with the materials requirements described in paragraphs 18 and 19. Nominal 2-inch by 4-inch stress-grade dimension lumber listed in Appendix A will be acceptable without site inspection prior to use.

21. Cleats should be evenly spaced throughout the length of the ladder between supports except on masons' ladders, on which the cleats should run the full length (height) of the ladder. Spacing, from top to top of cleats, should be 11.5-12.5 inches. Each cleat should be continuous members and extend the full width of the ladder on double-cleat ladders.

22. Cleats should be attached to the narrow face of rails, using three 10-penny nails for 1-inch by 4-inch lumber, and three

12-penny nails for 2-inch by 4-inch lumber. The nails shall be staggered to reduce splitting. Filler strips (blocks) of the same thickness as the cleats shall be cut snug and inserted between cleats and nailed to the side rails.

23. Do not permit dapping (or cutting into) the rails to house cleats.

Ladder installation

24. Set rails on level, even and solid footing; and use foot blocks or mud sills if necessary. Place job-made ladders at locations where there will be no danger of being struck by passing vehicles, equipment or falling objects. When ladders must be placed in passageways or other such thoroughfares, they should be protected by substantial barricades around their bases.

25. The permissible pitch shall range from vertical to 1 in 4 depending upon site conditions and ladder rail sizes (see Tables I



and II). In other words, the horizontal distance from the base of the ladder to the supporting surface shall not be greater than one-fourth the ladder working length. Ladders with spliced side rails shall be used at a pitch farther than 1 in 8.

26. Tops of ladders should extend approximately 36-42 inches above the top landing so workers getting on or off will have a solid handhold.

27. Horizontal handrails, mid-rails and toe-boards are necessary on either side of the

job-made ladder side-rail extensions when the ladder is used for access to an elevated work area.

28. Secure ladders to prevent displacement. At the top, nail the ladder or lash it with wire or rope to a secure object. At the bottom, secure it against movement by blocking, tying or another suitable method.

29. Solidly decked landings should be provided at the top of all ladders.

30. If protective coatings are considered desirable, only transparent coatings or wood

Table I: Minimum rail size for single-cleat ladders (nominal-dimension lumber)

Working Length (feet)	Pitch (H/L) (See Note 1)				
	Vertical	1/10	1/8	1/6	1/4
12	2x4	2x4	2x4	2x4	2x4
14	2x4	2x4	2x4	2x4	2x4
16	2x4	2x4	2x4	2x4	2x6
18	2x4	2x4	2x4	2x6	2x6
20	2x4	2x4	2x6	2x6	2x6
22	2x4	2x6	2x6	2x6	2x6
24	2x4	2x6	2x6	2x6	2x6

Table II: Minimum rail size for double-cleat ladders (nominal-dimension lumber)

Working Length (feet)	Pitch (H/L)				
	Vertical	1/10	1/8	1/6	1/4
12	2x4	2x4	2x4	2x4	2x4
14	2x4	2x4	2x4	2x4	2x6
16	2x4	2x4	2x6	2x6	2x6
18	2x4	2x6	2x6	2x6	2x6
20	2x4	2x6	2x6	2x6	(Note 2)
22	2x4	2x6	2x6	2x6	(Note 2)
24	2x4	2x6	2x6	2x6	(Note 2)

Notes:

1) Pitch is defined as H, the horizontal distance from the base of ladder to supporting surface, divided by working length L, length of rail from base to point of bearing at the top.

2) Stresses exceed capacity of 2x6 rails for this combination of height and pitch.



preservative should be used. Ladders shall not be painted with opaque coating.

tion Division of the National Safety Council, 1121 Spring Lake Drive, Itasca, IL 60143.

Inspection and maintenance

31. All job-made ladders, landings and lashings should be inspected daily or before each use, and any defects that have developed (or damage that has occurred) should be corrected immediately.

Sources of information

American National Standards Institute, 1819 L St., N.W., 6th Floor, Washington, DC 20036. *Safety Requirements for Job-Made Ladders*, A14.4-1979. Some material in this data sheet is reproduced (with permission) from this standard, copyright 1979 by the American National Standards Institute. Copies of the standard may be purchased from the American National Standards Institute.

Acknowledgement

This data sheet was revised by the Construc-

Appendix A: Acceptable stress-grade lumber for job-made ladders (note 1)

Species group	Minimum grade (Note 2)
Coast sitka spruce	Select structural [Note 3(f)]
Douglas fir-larch	No. 2 [Note 3(c), (d), (f)]
Douglas fir-south	No. 2 [Note 3(d)]
Eastern hemlock-tamarack	No.1[Note 3(a), (b), (f)]
Eastern spruce	Select structural [Note 3(a), (b)]
Hem-fir	No. 1 [Note 3(c), (d), (f)]
Lodgepole pine	Select structural [Note 3(d)]
Mountain hemlock	No. 1 [Note 3(c), (d)]
Northern pine	No. 1[Note 3(a), (b)]
Ponderosa pine-sugar pine	Select structural [Note 3(d), (f)]
Red pine	Select structural [Note 3(f)]
Sitka spruce	Select structural [Note 3(c)]
Southern pine	No. 2 [Note 3(e)]
Spruce-pine-fir	Select structural [Note 3(f)]
Western hemlock	No. 1 [Note 3(c), (d)]

Notes:

- (1) Used at 19 percent maximum moisture content.
- (2) Minimum fiber stress in bending $f_b = 1200 \text{ lbf/in}^2$ [pound-force per square inch 9psi]
- (3) All lumber shall be identified with a grademark of an ALSC-approved inspection agency under the rules set forth by the following rules-writing agencies:
 - a. Northeastern Lumber Manufacturers Association
 - b. Northern Hardwood and Pine Manufacturers Association
 - c. West Coast Inspection Bureau
 - d. Western Wood Products Association
 - e. Southern Pine Inspection Bureau
 - f. National Lumber Grades Authority - Canada

Appendix B: Permissible defects in wood used for ladders

Cleats - The slope of the grain for this lumber should be not less than 1 in 15. Knots are not permissible in the narrow faces of the ladder cleats and knots in the wide faces should not be bigger than 0.25 inch in diameter.

Side rails - This lumber should be as straight as possible, with a slope of the grain not steeper than 1 in 12. Knots are not permissible in the narrow faces of the lumber. Tight and sound knots of 0.5 inches or less in diameter are permissible in the wide faces if not more frequent than one in three feet and at least 0.5 inch back from a narrow face. Pitch and bark pockets not more than 0.125 inch wide, two-inches-long, and 0.5 inch deep are permitted in side rails, if they are not more frequent than one in every three feet. Black streaks in western hemlock are not considered an irregularity, except that chambers present in the streaks are limited by the specifications for pitch and bark pockets.

Appendix C: Glossary of wood defects

Knots - A knot is a segment of a branch or limb that was embedded in the tree and has been cut through in the process of manufacturing. An encased knot and an intergrown knot are shown in Figure 6.

Checks - A lengthwise separation of the wood that most often occurs across the annual growth rings.

Compression failure - A deformation (buckling) of the fibers due to excessive compression along the grain. This may appear as a wrinkle across the surface. In some cases compression failure may be present but not visible as wrinkles; in such cases it is often indicated by fiber breakage on end-grain surfaces.

Compression wood - An abnormal growth, primarily found in soft wood, characterized by relatively wide annual rings, usually eccentric, and comparatively large portion of summer wood (usually 50 percent or more) that most often merges into the spring wood without exhibiting a marked contrast in color.

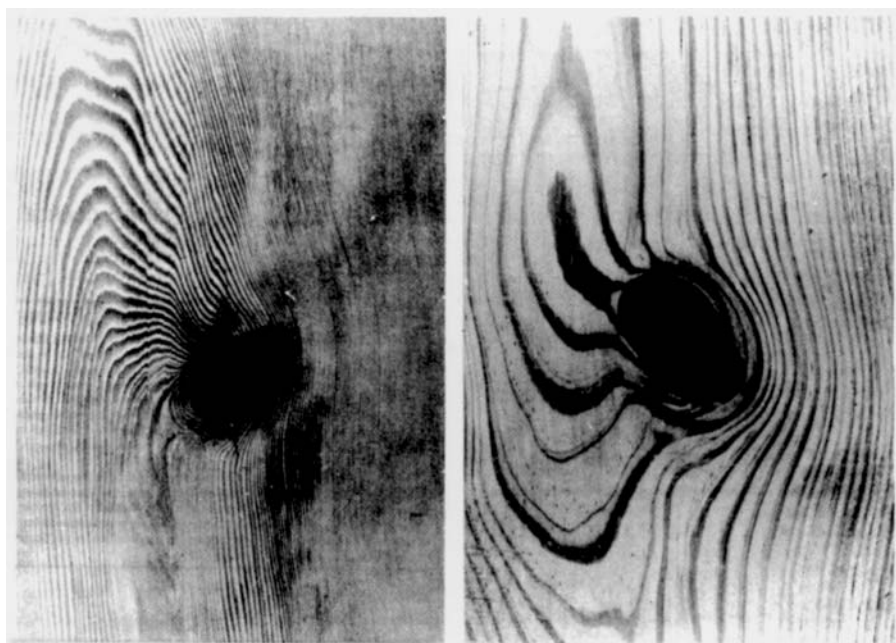

Figure 6. Examples of an encased knot (*left*) and an intergrown knot (*right*).
(Photo Courtesy of Forest Products Laboratory, U.S. Forest Service)



Decay - The disintegration of wood due to the action of fungi. (This is also known as rot or rot.)

Pitch and bark pockets - A pitch pocket is an opening extending parallel to the annual growth rings that contains or has contained pitch in a solid or liquid form. A bark pocket is an opening between annual growth rings that contains bark. Bark pockets appear as dark streaks on radial surfaces and as rounded areas on tangential surface.

Shakes - Separation along the grain, most commonly occurring between annual growth rings.

Wane - Bark or the lack of wood on the corner of a piece of lumber. The cause is not important.

Copyright 2006 National Safety Council.

All rights reserved.

Although the information and recommendations contained in this publication have been compiled from sources believed to be reliable, the National Safety Council makes no guarantee as to, and assumes no responsibility for, the correctness, sufficiency, or completeness of such information or recommendations. Other or additional safety measures may be required under particular circumstances.